

*NOT FOR HOME USE*

Owner's Manual For:

# JARVIS Wellsaw

## PORTABLE POWER SAW

# MODEL 404

<b>Table Of Contents</b> .....	<b>Page</b>
•Notice to Employer and Safety Director .....	2
•Notice to Operators, Maintenance and Cleanup Personnel .....	3
•Parts Diagram .....	4
•Parts List .....	5
•Specifications .....	6
•Installation Instructions .....	6
•General Safety Instructions .....	7
•Operation Instructions .....	8
•Maintenance Instructions .....	9

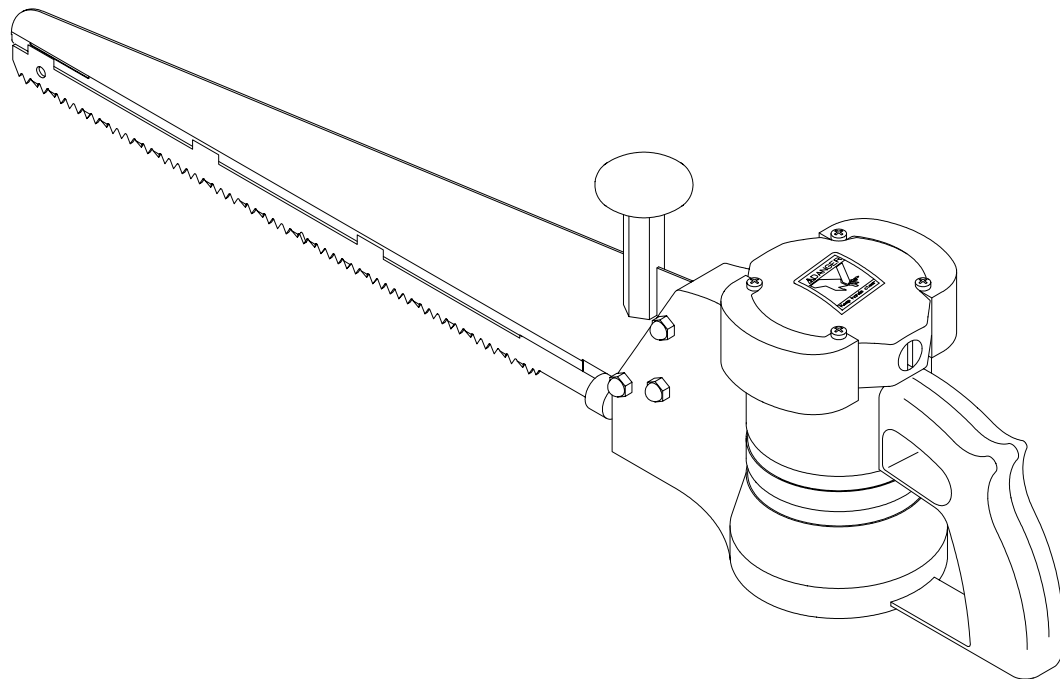

**JARVIS**®

6205006::

**PRODUCTS CORPORATION**

33 ANDERSON ROAD, MIDDLETOWN, CONNECTICUT 06457-4926  
UNITED STATES OF AMERICA E-MAIL [jarvis.products.corp@snet.net](mailto:jarvis.products.corp@snet.net)  
FAX 860-347-6978 TEL. 860-347-7271 [WWW.jarvisproducts.com](http://WWW.jarvisproducts.com)



**NOTICE TO EMPLOYER AND SAFETY DIRECTOR**  
***AVOID INJURY***

1. **Remove and repair** any tool that malfunctions. All personnel must be instructed to remove any malfunctioning equipment.
2. **Ensure** that all employees who use this tool are trained in the proper use of this tool and are aware of the dangers that may arise if they do not follow the procedures outlined in this brochure.
3. Enclosed are four (4) copies of “**NOTICE TO OPERATORS, MAINTENANCE AND CLEAN-UP PERSONNEL.**” Post one copy on the employees’ bulletin board; give one copy to operator(s); give one copy to the maintenance foreman; and give one copy to the sub-contract cleanup / internal cleanup foreman. *Additional copies will be provided upon request.*
4. The tool is designed and intended to be powerful. That fact should be obvious to your employees, but you must emphasize it to them.
5. **Never** make modifications or alterations to the tool. *Replace any missing or illegible labels.*
6. **Always** disconnect the tool from its power supply when it is not in use.
7. **Follow** our installation and maintenance instructions for proper installation and care of the tool.
8. **Ensure** that employees wear eye protection in accordance with OSHA’s eye and face protection requirements (29 CFR 1910.133) at all times.
9. **Hand/Wrist/Arm** injury and other Cumulative Trauma Disorders may result from repetitive work, motion or vibration. You must make your employees aware of hazards, symptoms of injury and appropriate prevention. See OSHA’s “Ergonomics Program Management Guidelines for Meat Packing Plants.”
10. **Avoid** injury. Do not permit the tool to be misused.
11. **If you resell or distribute** a Jarvis product, you must provide the purchaser with the appropriate safety sheets and tool brochure. *Additional copies of safety sheets and tool brochures will be provided upon request.*



**NOTICE TO OPERATORS, MAINTENANCE AND CLEANUP PERSONNEL**

***REMOVE ANY MALFUNCTIONING TOOL FROM SERVICE***

***REPORT ANY PROBLEMS TO YOUR SUPERVISOR***

1. **Always** wear eye protection in accordance with OSHA's eye and face protection requirements (29 CFR 1910.133), and when needed, a dust mask.
2. **Do not** operate near flammable liquids or in gaseous atmospheres.
3. **Do not** operate in outdoor locations or in damp or wet locations.
4. **Do not** overreach; keep proper footing and balance when using the tool.
5. **Disconnect** the power supply in accordance with OSHA's lockout/tagout procedures (29 CFR 1910.147) before changing the blade.
6. **Disconnect** the power supply in accordance with OSHA's lockout/tagout procedures (29 CFR 1910.147) before performing any repair or maintenance.
7. **Disconnect** the power supply - or have the power supply disconnected - in accordance with OSHA's lockout/tagout procedures (29 CFR 1910.147) before performing any cleanup.
8. **Disconnect** the power supply when the tool is not in use.
9. **Never** put fingers, hands or other parts of the body on the cutting edge of the blade or in the cutting path.
10. **Test** the tool prior to use or daily. **Depress** the trigger and the tool should start. **Release** the trigger and the tool should stop. *If the tool malfunctions, remove it from service and report or repair it immediately.*
11. **Never** depress the trigger unless you are going to use or test the tool.
12. **Never** make any alterations to the tool. *Report or replace any missing or illegible labels.*
13. **Always** use both hands when starting and operating the tool to avoid the risk of possible "kick back" or "recoil." Continue holding the tool with both hands until the saw blade comes to a complete stop.

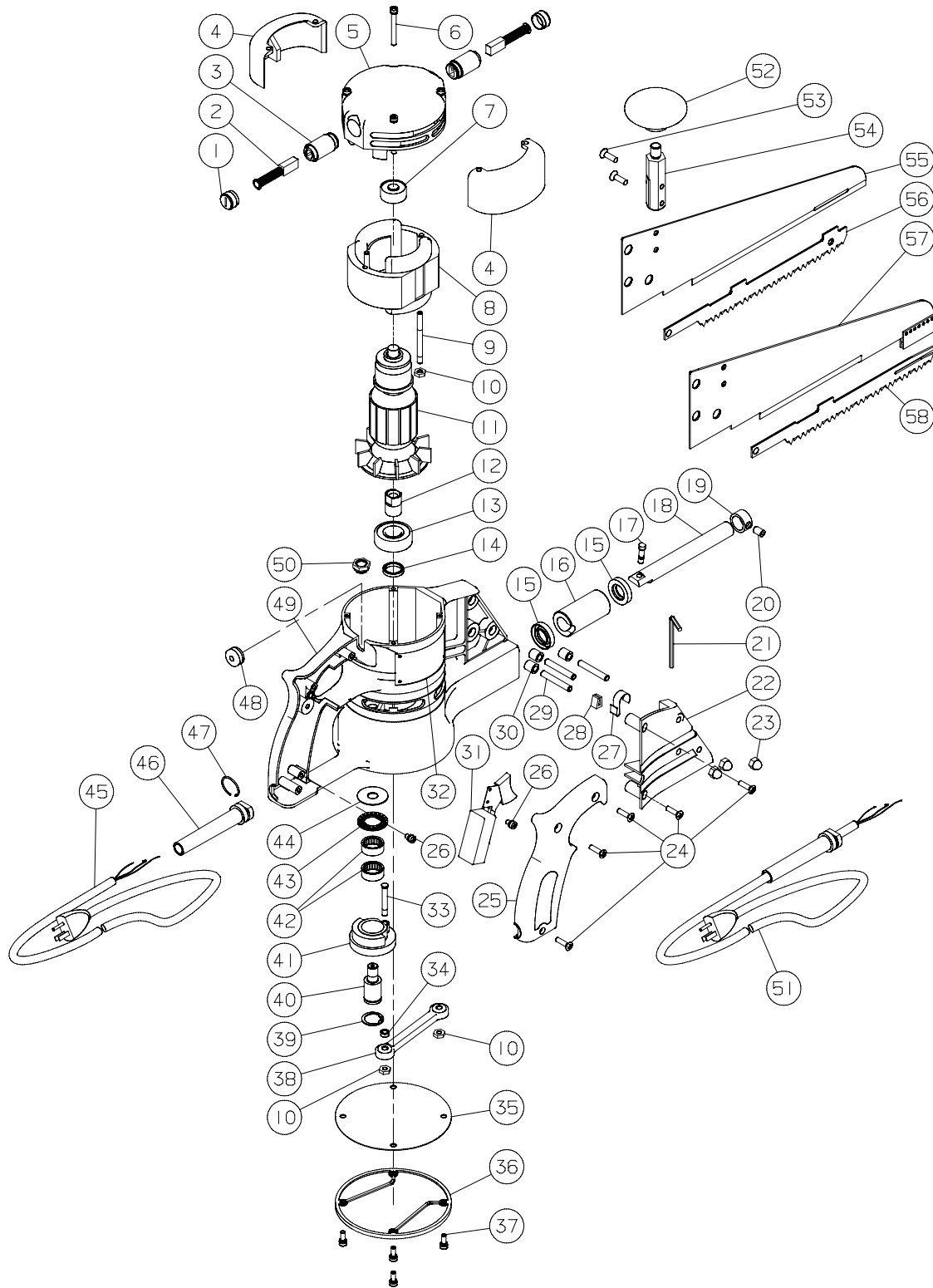

ITEM	JARVIS PART NO.	OLD PART NO.	PART NAME	QTY
1	1063112	501022-005	Brush Cap	2
2	1063111	501022-004	Brush and Spring	2
3	1063110	501022-003	Brush Holder	2
4	1015006	501174	Deflector	2
5	1002191	501002	Top Cap	1
6	1055428	100101-004	Screw	4
7	1021215	100403-003	Ball Bearing	1
8	1063119	501224-003	Stator, 115V	1
	1063120	501224-004	Stator, 230V	1
9	1027040	501021	Stator Stud	2
10	1007164	100105-001	Lock Nut	4
11	1063117	501224-001	Armature, 115V	1
	1063118	501224-002	Armature, 230V	1
12	1026072	501225	Pinion Gear	1
13	1021227	100422-004	Ball Bearing	1
14	1035193	501120-001	Seal	1
15	1035192	501103	Seal	2
16	1036116	501171	Bushing	1
17	1027041	501046	Rod Stud	1
18	3065010	501172	Push Rod and Stud	1
19	1012050	501350	Clamp Ring	1
20	1055422	100034-038	Set Screw, 1/4 inch	1
21	8030031	100099-001	Hex Key	1
22	1002206	501003-001	Blade Support Cover	1
23	1007162	100022-006	Cap Nut	6
24	1055439	100102-002	Screw	5
25	1002203	501004	Handle Cover	1
26	1055438	100101-003	Screw (set of 12)	3
27	1012046	501042	"S" Clip	1
28	1012047	501043	"U" Clip (rubber)	1
29	1027048	501272	Stud	3
30	1036120	501273	Insert Bushing	3
31	1005038	100739-001	Switch	1
32	1017033	501187	Info Label 115V, Eng.	1
	1017034	501179	Info Label 230V, Eng.	1
	1017054		Info Label 115V, French	1
	1017234		Info Label 230V, French	1
	1045013		Label Retaining Rivet	4
33	1027043	501081	Drive Stud	1
34	1029185	501082	Spacer	1
35	1035191	501008	Gasket	1
36	1002193	501005	Bottom Plate	1
37	1055426	100101-001	Screw (set of 12)	4
38	3028030	501053	Connecting Rod & Brg	1
39	1013310	100069-013	Snap Ring	1
40	1020133	501377	Gear Shaft	1
41	3026024	501223	Gear and Stud (33)	1
42	1021216	100424-001	Needle Bearing	2
43	1021218	100425-001	Needle Thrust Bearing	1
44	1004149	100426-001	Thrust Bearing Race	1
45	3001011	501337	Cord and Plug, 230V	1
46	1063125	501294	Strain Relief	1
47	1013137	501295	Clamp Ring	1
48	1063109	100647	Grommet	1
49	1016199	501001-006	Housing	1
50	1007166	501376	Gear Shaft Nut	1

ITEM	JARVIS PART NO.	OLD PART NO.	PART NAME	QTY
51	3001008	501006	Cord and Plug with strain relief, 115V	
	3001017		European Line Cord with strain relief, without plug.	
52	1006021	501066	Knob	1
53	1055429	100102-003	Screw	2
54	1027042	501065	Handle Stud	1
	1027049	501378	Heavy Duty Stud	

blades, blade supports  
and accessories

ITEM	JARVIS PART NO.	OLD PART NO.	PART NAME	QTY
55	1058071	501175T	Blade Support 8" End Cut	1
	1058070	501128T	Blade Sup. 16" End Cut	
56	1023122	501246	Blade 8" End Cutting	1
	1023121	501247	Blade 16" End Cutting	
57	1058075	502077T	Blade Sup. 8" Heavy Duty	1
	1058074	502076T	Blade Sup. 16" Heavy Duty	
58	1023123	501319	Blade 8" Heavy Duty	1
	1023124	501320	Blade 16" Heavy Duty	

replacement kits

ITEM	JARVIS PART NO.	OLD PART NO.	PART NAME
	3063010	501351-001	Armature and Bearing (no pinion gear) 115V
	3063011	501351-002	Armature and Bearing (no pinion gear) 230V
	3063007	501235-001	Armature, Bearing and Pinion Gear, 115V
	3063008	501235-002	Armature, Bearing and Pinion Gear, 230V
	3063013	501232	Armature and Pinion, 115V
	3063014	501233	Armature and Pinion, 230V
	3001008	501006	Cord Assembly, 115V
	3001010	501089	Cord Assembly, 230V
	3001017		Cord Assy, 230V Europe
	3026023	501088	Gear And Bearing Assy
	3016119	501169-001	Housing & Bushing Assy
	1062003		Gear Grease (1 lb can)

### SPECIFICATIONS

Motor Power	1 hp	745 W
Operating Volt/Amp	230V/3.5A, 1 phase, 50/60 Hz	115V/7A, 1 phase, 50/60 Hz
Stroke	1.13 in	29 mm
Blade Speed	8000 strokes / min	
Control Handle	Single Trigger	Electric
Blade Length	8 in	203 mm
	16 in	406 mm
Overall Length (w/16 in blade)	32 in	813 mm
Weight (w/o blade)	9.8 lbs	4.5 kg

### INSTALLATION INSTRUCTIONS

These instructions have been prepared to assure you of satisfactory operation through proper use of your **Jarvis** Wellsaw.

*Read them carefully and keep them for future reference.*

#### POWER SUPPLY

Your **Jarvis** Wellsaw operates on 50 or 60 Hz., single phase alternating current. Its voltage rating is indicated on the name plate (either 115 or 230 Volt). If an extension cord is to be used, be sure that the wire size is adequate to maintain full line voltage to the tool.

#### GROUNDING

Your **Jarvis** Wellsaw should be grounded to prevent the user from electric shock or *electrocution*. The **Jarvis** Wellsaw is equipped with an approved three conductor cord and three prong grounding-type plug to fit the proper grounding-type receptacle. The green conductor in the cord is the grounding wire. Never connect the green

wire to a live terminal. If your **Jarvis** Wellsaw is the 115 volt model, it has a plug that looks like figure "A". If your **Jarvis** Wellsaw is the 230 volt model, it has a plug that looks like figure "B".

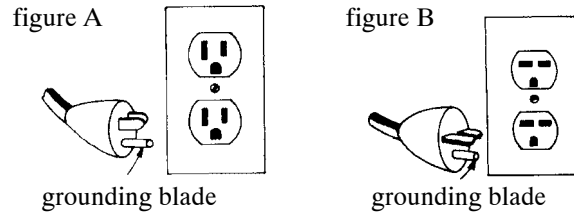

Do not use any adapters with the **Jarvis** Wellsaw

#### EXTENSION CORDS

Make sure your extension cord is in good condition. When using an extension cord, be sure to use one heavy enough to carry the current your **Jarvis** Wellsaw will draw. An undersized cord will cause a drop in line voltage resulting in loss of power and overheating. The table below shows the correct size to use depending on cord length and nameplate ampere rating. If in doubt, use the next heavier gage. The smaller the gage number, the heavier the cord.

Minimum Wire Gage for Extension Cords

Volts	Total Length of Cord in Feet			
	0-25	26-50	51-100	101-150
120	0-25	26-50	51-100	101-150
240	0-50	51-100	101-200	201-300

Amp Rating	Wire Size (AWG)			
0-6	18	16	16	14
6-10	18	16	14	12

When tool is used outdoors, use only extension cords labeled for outdoor use.

## **GENERAL SAFETY INSTRUCTIONS For Operators, Employers and Maintenance Personnel**

**WARNING:** When using electric tools, basic safety precautions should always be followed to reduce the risk of fire, electric shock and personal injury, including the following:

1. **READ ALL INSTRUCTIONS.**
  - Know your **Jarvis** Wellsaw and understand safety notices, manuals and instructions in the literature provided. Become familiar with the **Jarvis** Wellsaw, its dangers, limitations and applications.
2. **INSTALL THE TOOL PROPERLY.**
  - Ground the tool. See instructions provided in the installation section of this manual.
  - Use the proper extension cord. See instructions provided in the installation section of this manual.
3. **USE THE RIGHT TOOL AND ATTACHMENTS.**
  - Select the proper tool to do the job. The **Jarvis** Wellsaw is designed for meat and bone cutting; wood cutting; non-woven and geo-textile cutting. Do not use the **Jarvis** Wellsaw for non-intended purposes.
4. **KEEP WORK AREAS CLEAN AND WELL LIT.**
  - Cluttered, oily and poorly lit work areas invite accidents.
  - Keep visitors a safe distance from the work areas.
5. **AVOID DANGEROUS ENVIRONMENTS.**
  - Do not expose the power tool to rain.
  - Do not use the tool in presence of flammable liquids or gases.
6. **WEAR PROPER APPAREL.**
  - Avoid being pulled by moving parts of the **Jarvis** Wellsaw. Do not wear loose clothing or dangling objects. Restrain long hair.
  - Wear safety glasses when operating the tool.
7. **MAINTAIN THE JARVIS WELLSAW AND ACCESSORIES WITH CARE.**
  - Keep the **Jarvis** Wellsaw sharp and clean for the best and safest performance.
  - Follow the instructions for lubricating and changing the blades.
  - Inspect the **Jarvis** Wellsaw regularly. If the **Jarvis** Wellsaw is malfunctioning, remove it from service and report any problems to your supervisor immediately.
  - Keep the handles dry, clean and free from oil and grease.
8. **STAY ALERT.**
  - Watch what you are doing and use common sense.
9. **SAVE THESE INSTRUCTIONS.**

## OPERATION INSTRUCTIONS

Before starting regular operation of the **Jarvis** Wellsaw, we recommend that you make a few cuts with a fine pitch blade to acquaint yourself with the operation of the tool before using any of the coarser blades.

### A. AVERAGE CUTTING AND RIPPING:

1. Place your work piece on a solid support at a convenient working height.
2. Adjust the material so that the line of cut will be close to the support. Secure it firmly.
3. To prevent starting torque of the motor from pulling the saw away from line of cut, the operator should make a few short strokes until the blade has cut into the material about 1/4 inch before squeezing trigger switch.
4. **Both hands should be on the saw at all times while cutting. Continue holding the tool with both hands until the saw blade comes to a complete stop.**
5. The saw should be kept at a 90 degree angle to the work piece while cutting material that is thicker than 1 inch.
6. The saw should be pushed firmly into the material while cutting.
7. Do not allow the saw blade or the blade support to leave the work piece while cutting.
8. Never allow the saw blade to float into the material while cutting.
9. Never permit any part of the saw, except the blade and the blade support, to contact the work piece during the cut.

### B. LARGE CROSS SECTIONS:

1. Rocking the saw in the cut will speed up the cutting action.

### C. SINKING THE BLADE THROUGH A SURFACE:

1. Your power hand saw is not designed for regular use in starting its own hole by sinking blades through a surface, commonly called "plunge cutting". If attempted, the operator must:
  - a. Keep the saw blade as parallel to the work as possible.
  - b. Immediately, as the blade makes contact with the work piece, start to draw the saw back slowly from the starting point.
  - c. Repeat the operation outlined in "b", if necessary.
  - d. Have room to draw the saw at least 4-6 inches before cutting through a 1 inch thickness.
  - e. Do not force the saw blade, but keep it moving slowly on the draw back from the starting point. After a break through cut has been made and the end of the blade support extends through the material at least 1-1/2 inches, the saw may be tipped to a normal cutting angle.

### D. NOT FOR CUTTING SMALL RADII:

### E. ALWAYS KEEP A SHARP BLADE ON THE SAW:

1. Cutting with a dull or badly worn blade can overload the saw and cause damage from overheating.
2. New blades can be purchased from **Jarvis**.



## MAINTENANCE INSTRUCTIONS

**Always disconnect the saw from its power supply before performing any maintenance.**

*Item numbers: refer to the parts diagram on page 4.*

### A. LUBRICATION:

1. The gear case should be kept 1/3 full of grease. To check the grease level, remove the bottom plate (item 36) and its gasket (item 35). It should be checked every thirty days for saws that are used moderately and every two weeks for saws that are used daily. If replacement grease is required it should be obtained from **Jarvis**.

### B. BLADE SUPPORT INSTALLATION:

1. Tap (3) inserts (item 30) gently into the bores on blade support clamp (item 22).
2. Align the blade support clamp (item 22) onto saw housing (item 49), making sure the inserts stay in place.
3. Assemble (3) studs (item 29) with cap nuts (item 23) and place them through the saw housing and the blade support clamp.
4. Draw down all (3) cap nuts (item 23) evenly until the inserts are bottomed out into the saw housing.
5. Remove the cap nuts (item 23) and the blade support clamp (item 22). (The inserts should now be properly set into the saw housing).
6. Assemble blade support (item 55 or 57) over the inserts on the saw housing. Place the blade support clamp (item 22) on the saw housing and fasten it with the studs (item 29), the cap nuts (item 23) and the phillips screws (item 24).
7. Install handle stud (item 54) using two larger phillips screws (item 53).

### C. BLADE REMOVAL:

NOTE: Your **Jarvis** Wellsaw is equipped with a hex key (item 21) for removing the blade. This wrench is located in the housing directly behind the blade support knob (item 52).

1. Insert the hex key through the hole in the outer end of blade (item 56 or 58) and pull the blade to the outer end of stroke.
2. Loosen the blade holding set screw (item 20) about 1/2 turn.
3. Reinsert the hex key in the hole at the outer end of the blade and pull the blade out.

### D. BLADE INSTALLATION:

1. Insert hex key (item 21) into set screw (item 20).
2. Thread the set screw (item 20) into the hole in the end of push rod (item 18). Do not tighten.
3. *STANDARD BLADE SUPPORT (End Cutting):*
  - a. Align blade (item 56) with blade support (item 55). *The blade should extend approximately three inches from the end of the blade support.*
  - b. Slide the blade onto the blade support until the crimp in the blade is touching the end of the blade support.
  - c. Use a rubber hammer and tap the end of the blade towards the body of the saw until the crimp in the blade slides into the slot in the blade support.

*HEAVY DUTY BLADE SUPPORT (Heavy Duty):*

- a. Place the grooved end of blade (item 58) into the guide in the blade support (item 57).

- b. Slide the blade over the blade support towards the body of the saw. *Make sure that the tabs on the blade extend over each side of the blade support.*
- Slide the blade into the push rod as far as it will go.
  - Tighten the set screw with the hex key.
- E. GENERAL DISASSEMBLY:**
- Remove blade (item 56 or 58) and blade support (item 55 or 57).
  - Remove handle cover (item 25).
  - Remove switch (item 31). Remove the top two wires by inserting a 1/16 inch diameter pin punch directly adjacent to the stator wires.
  - Remove brush cap (item 1) and brushes (item 2).
  - Remove deflectors (item 4).
  - Slide off top cap (item 5) - stator (item 8) will be attached.
  - Remove armature (item 11). Hold the armature in one hand and tap housing (item 49) with a rubber hammer with the other hand to loosen the armature. (*Pinion gear - item 12 - on the armature has a left hand thread.*)
  - Remove bottom plate (item 36) and gasket (item 35).
  - Insert a small block of wood between the connecting rod (item 38) and the housing (item 49) to stop the rotation of the connecting rod. Remove lock nuts (item 10). Remove the connecting rod.
  - Using a 5/16 inch hex key, loosen gear shaft (item 40) - *left hand thread*. Be sure not to spin gear stud nut (item 50). Remove items 33 and 41-44.
  - Remove the push rod and stud (item 18) through the center of the housing.
  - Clean the gear housing cavity to remove any contaminated lubricant.
  - Remove and replace any faulty parts and reassemble by reversing these steps.
- NOTE (when reassembling):*
- Step 10: Use *Loctite 271* on gear shaft nut (item 50) before fastening gear stud (item 40).
  - Step 7: Reassemble armature (item 11) in housing (item 49) by using a center punch to tap the armature until its bearing is fully seated.

**JARVIS**®  
6205006:

**PRODUCTS CORPORATION**

33 ANDERSON ROAD, MIDDLETOWN, CONNECTICUT 06457-4926  
UNITED STATES OF AMERICA E-MAIL [jarvis.products.corp@snet.net](mailto:jarvis.products.corp@snet.net)  
FAX 860-347-6978 TEL. 860-347-7271 [WWW.jarvisproducts.com](http://WWW.jarvisproducts.com)

# JARVIS

**PRODUCTS CORPORATION**

JARVIS®

6205006:

**PRODUCTS CORPORATION**

33 ANDERSON ROAD, MIDDLETOWN, CONNECTICUT 06457-4926  
UNITED STATES OF AMERICA E-MAIL [jarvis.products.corp@snet.net](mailto:jarvis.products.corp@snet.net)  
FAX 860-347-6978 TEL. 860-347-7271 [WWW.jarvisproducts.com](http://WWW.jarvisproducts.com)