

SF-260 RAPID SAUSAGE FILLER

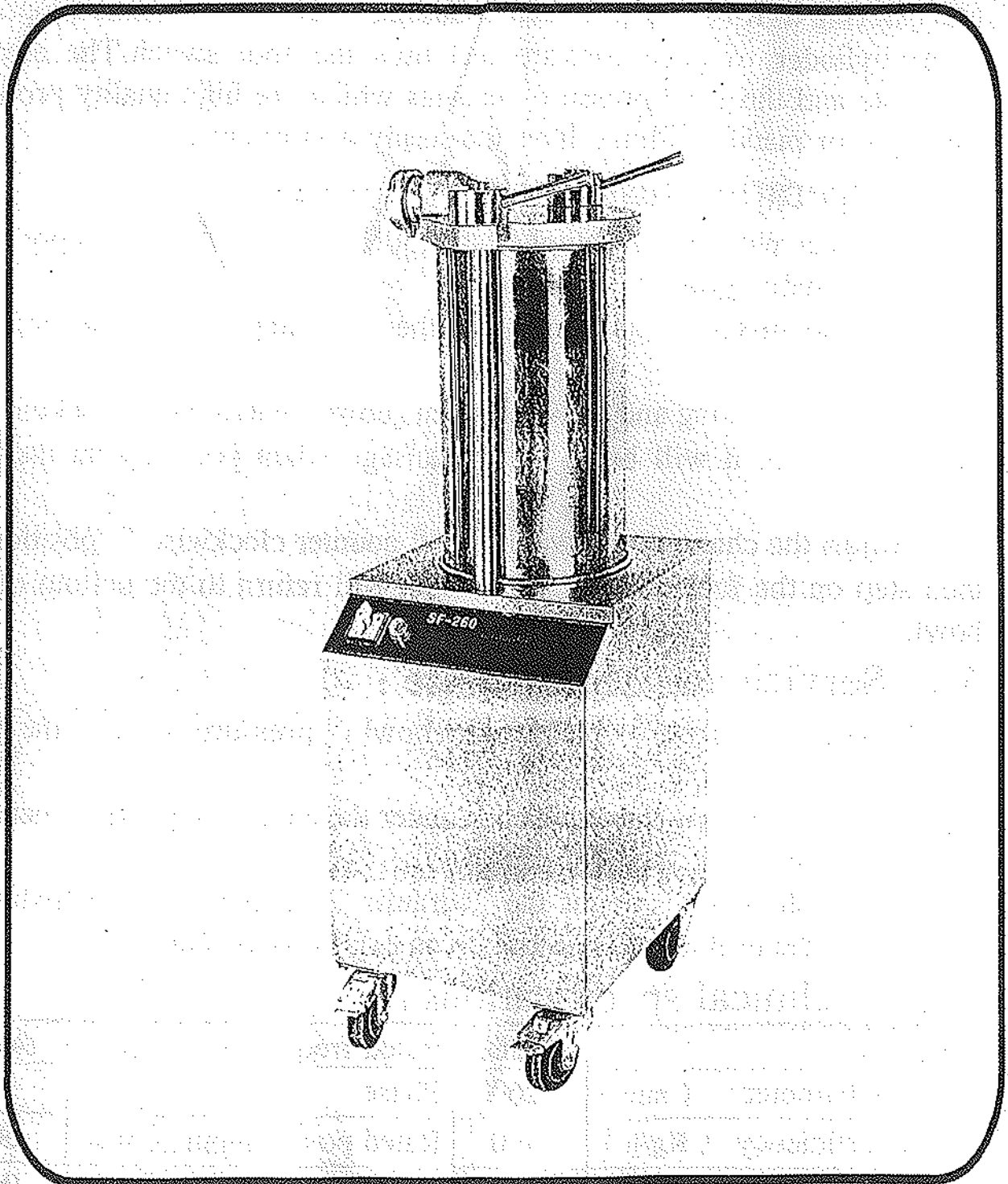

SF-260RAPID SAUSAGE FILLER

1、 Introduction :

SF-260rapid sausage filler is suitable for meat processing enterprise and catering to fill sausage and ham sausage , etc.The machine adopts the hydro-cylinder to push forward and uses the foot switch.The electric elements and the fluid-pressure elements,which are high-quality products imported or made in China, have the steady performance.

2、 Operating Instruction:

a、 Connect with power supply 220V,50Hz,and the power supply must have the reliable ground protection.

b、 Put the mixed meat filling into the bowl and tighten the pressure cover.

c、 Put on the casing and adjust the changeover switch on “ clockwise ” position , then it will begin filling sausage when you step on the foot switch.

d、 Adjust the changeover switch on “ counter clockwise ” position ; then step on the foot switch , the piston will return to the bottom of the bowl.

3、 Service and Maintenance :

1、 Before or after use , please clean bowl , pressure cover , the body and the pipe.

2、 Turn the pressure valve which is under the connecting part , then you can adjust the return speed of piston.

3、 Please do not dismount the hydraulic elements , If the hydraulic system has the problem please call on an expert to maintain.

4、 Technical specifications :

Model	SF-260	Rated frequency (Hz)	50/60
Bowl diameter (mm)	260	Phase	~
Max efficiency (Kg/h)	400	Rated power input (W)	600
Rated voltage (V)	110/220	Weight (Kg)	95

MACHINE ILLUSTRATIONS

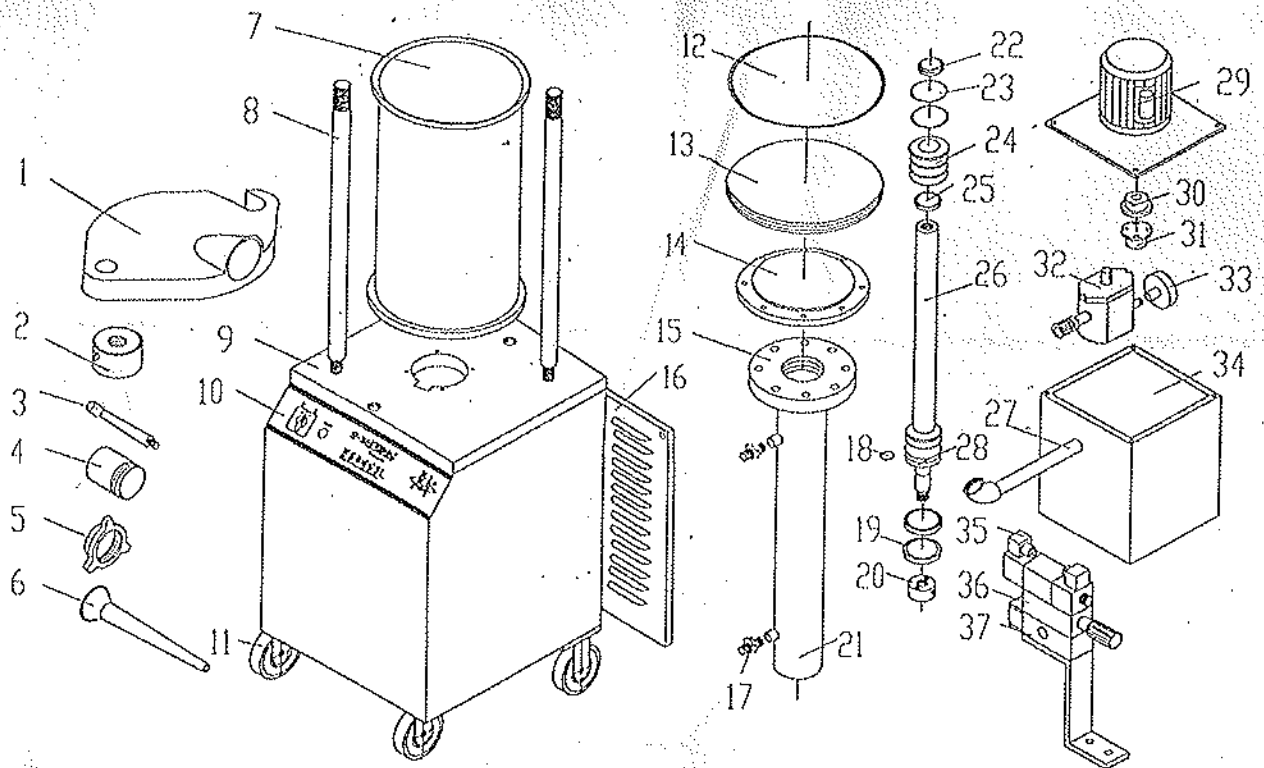

PARTS LIST

Illu.	Code	Name of Part	qty
1	SF-260-1-1	Top cover	1
2	SF-260-2-1	Lock screw	2
3	SF-260-2-2	Lock handle	2
4	SF-260-1-2	Pipe	1
5	SF-260-1-3	Lock cover	1
6	SF-260-1-4	Tap	1
7	SF-260-3	Bowl	1
8	SF-260-4	Bolt	2
9	SF-260-5-1	Plate	1
10	SF-260-5-2	Label	1
11	SF-260-4	Wheel	4
12	GB3452.1-92	O-shaped joint washer	2
13	SF-260-6-1	Bowl piston	1
14	SF-260-6-2	Support	1
15	SF-260-7-1	Flange	1
16	SF-260-5	Back plate	1
17	SF-260-8-9	Pipe	2
18	GB3452.1-92	O-shaped joint washer	1
19	B10708.1-89	Y-shaped joint washer	2
20	SF-260-7-2	Solid plate	1
21	SF-260-7	Tank	1
22	SF-260-7-3	Piston cover	1
23	GB3452.1-92	O-shaped joint washer	2
24	SF-260-7-5	Guide sheath	1
25	GB10708.1-89	Y-shaped joint washer	1
26	SF-260-7-4	Piston bolt	1
27	SF-260-8-1	Blast pipe	1
28	SF-260-6	Piston	2
29	220V,370W	Motor	1
30	SF-260-10	Top axle joint	1
31	SF-260-11	Bottom axle joint	1
32	1.6L/min	Gear pulp	1
33	SF-260-12	Oil filter	1
34	SF-260-8-2	Oil box	1
35	4DO-B6C-T	Changeable magnetic valve	2
36	L1-10	Pressure regulating valve	1
37	SF-260-13	Perforated plate	1

TECHNICAL SPECIFICATIONS

Phase	~
Rated voltage	110V/220V/230V/240 V
Rated cycle	50/60Hz
Rated power input	600W
Productivity	400kg/h
Dimension	400x478x1240mm

